

Capture Data and Knowledge in Models for Remote Monitoring

SIEMENS



Christer Karlsson, PhD
Siemens Industrial Turbomachinery AB

Siemens Industrial Turbomachinery AB

Outline

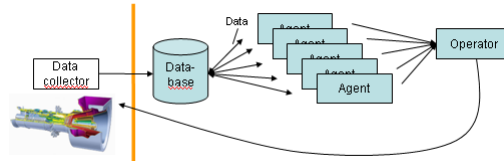

SIEMENS

- Background
- Purpose, Goal
- Problem domain
- Specialists
- Models
- Examples
- Aspects on models
- Conclusions

Background

Gas turbine trends

Reliability ↑

Life-time ↑

Performance ↑

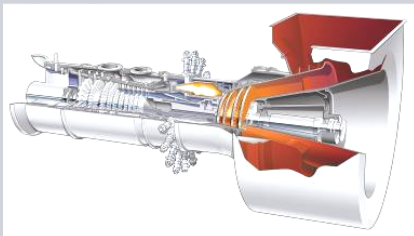

Background

Gas turbine trends

These trends drive e.g.:

Reliability ↑



Remote monitoring

Life-time ↑



Materials, cooling

Performance ↑



Complex design

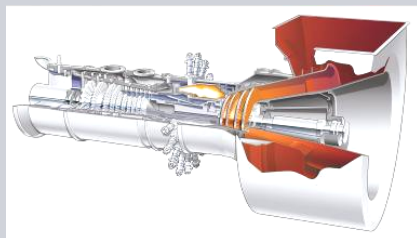

Remote Analysis

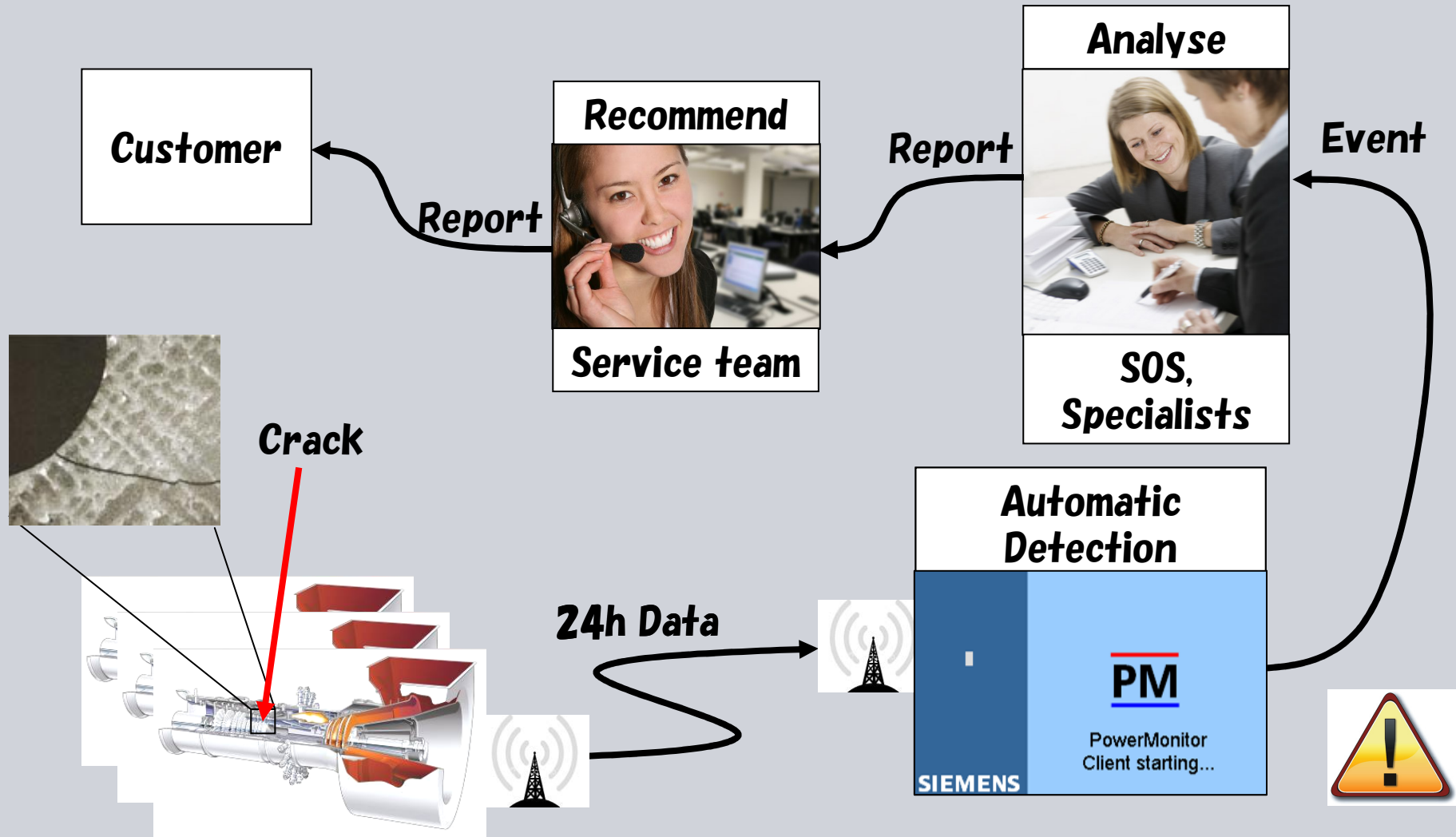

Problem domain

Complex process

Deteriorates over time

Fast/Slow mechanisms

Require high reliability

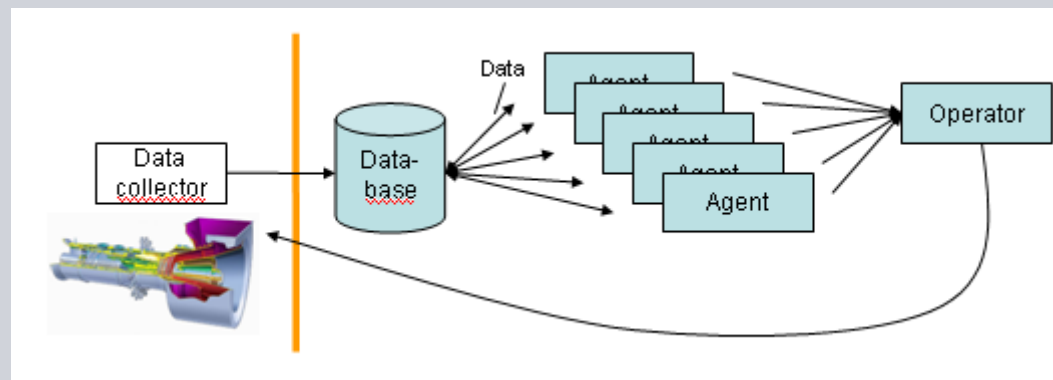

Sources of information

- Specialist knowledge
- Tests
- Operation
- Simulation

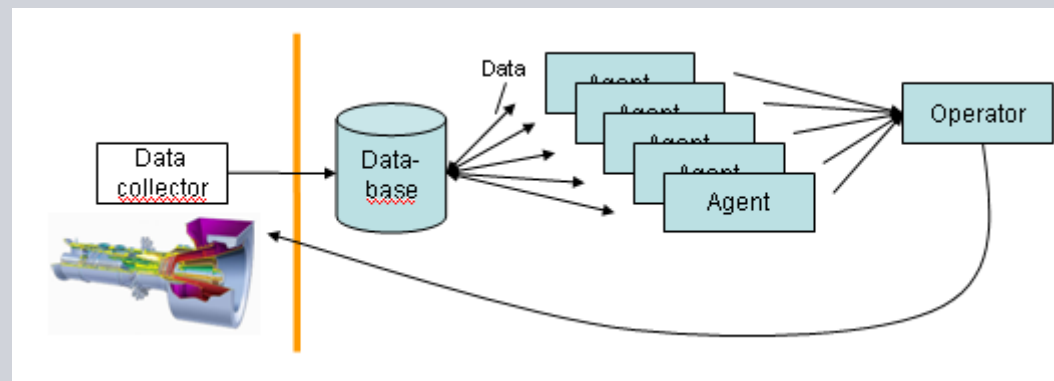

Sources of information

- Specialist knowledge
- Tests
- Operation
- Simulation

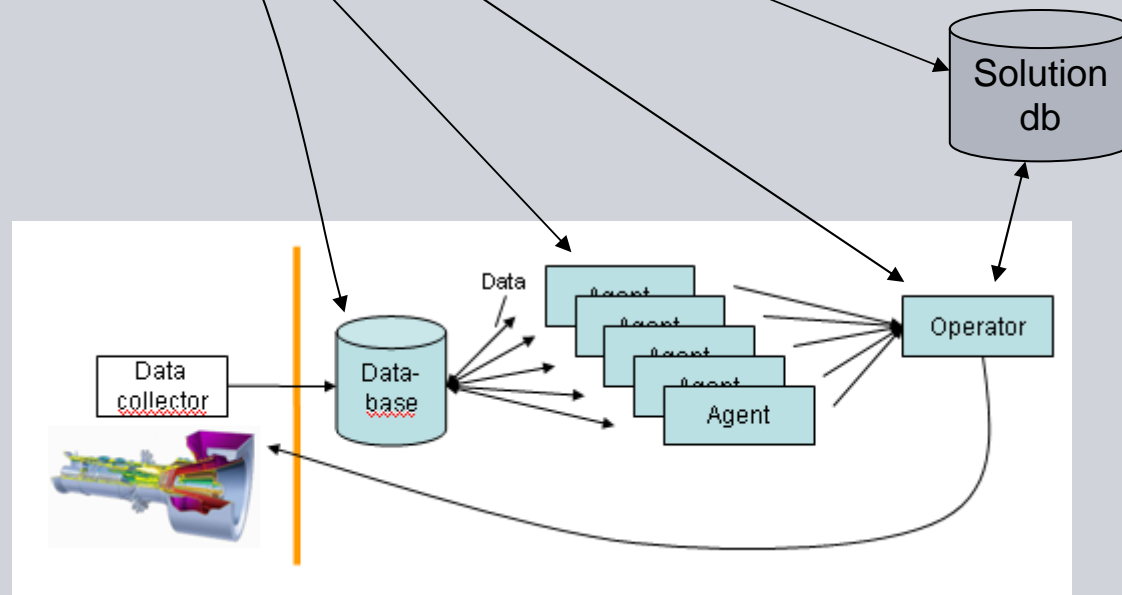

Experiences - specialist

- Reproduce specialist method – is that possible?
- Nothing is obvious – define constraints
- The real challenge - interpret specialist

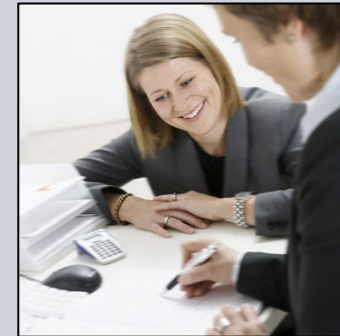

Experiences - models

- One type of model to solve it all?
- Hybrid models – the best from two worlds?
- Special algorithms/models – the tailor-made solution
- Constraints – telling what to not model

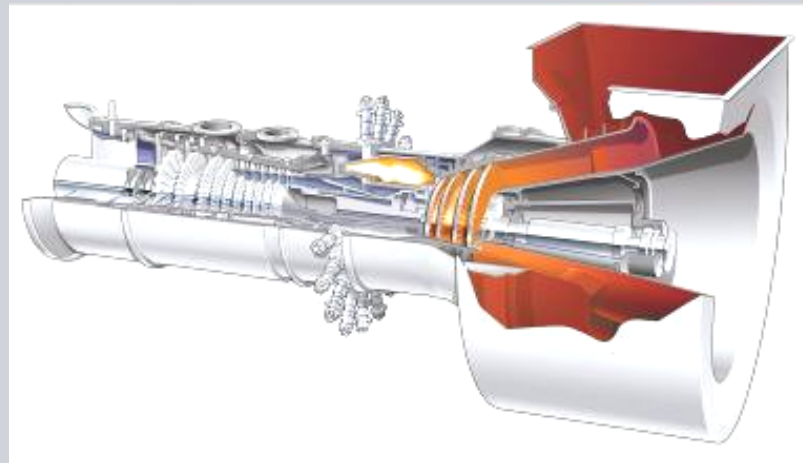

Early Warning System

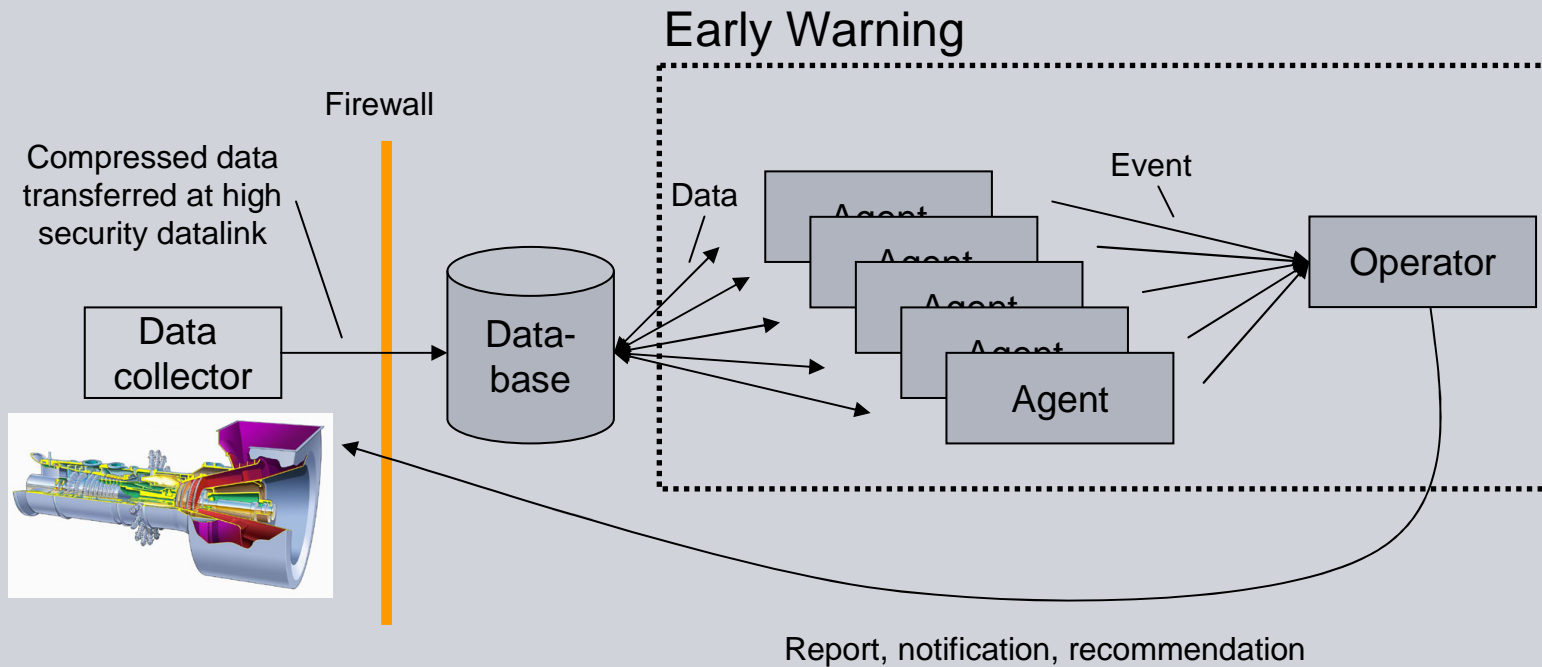

System constraints

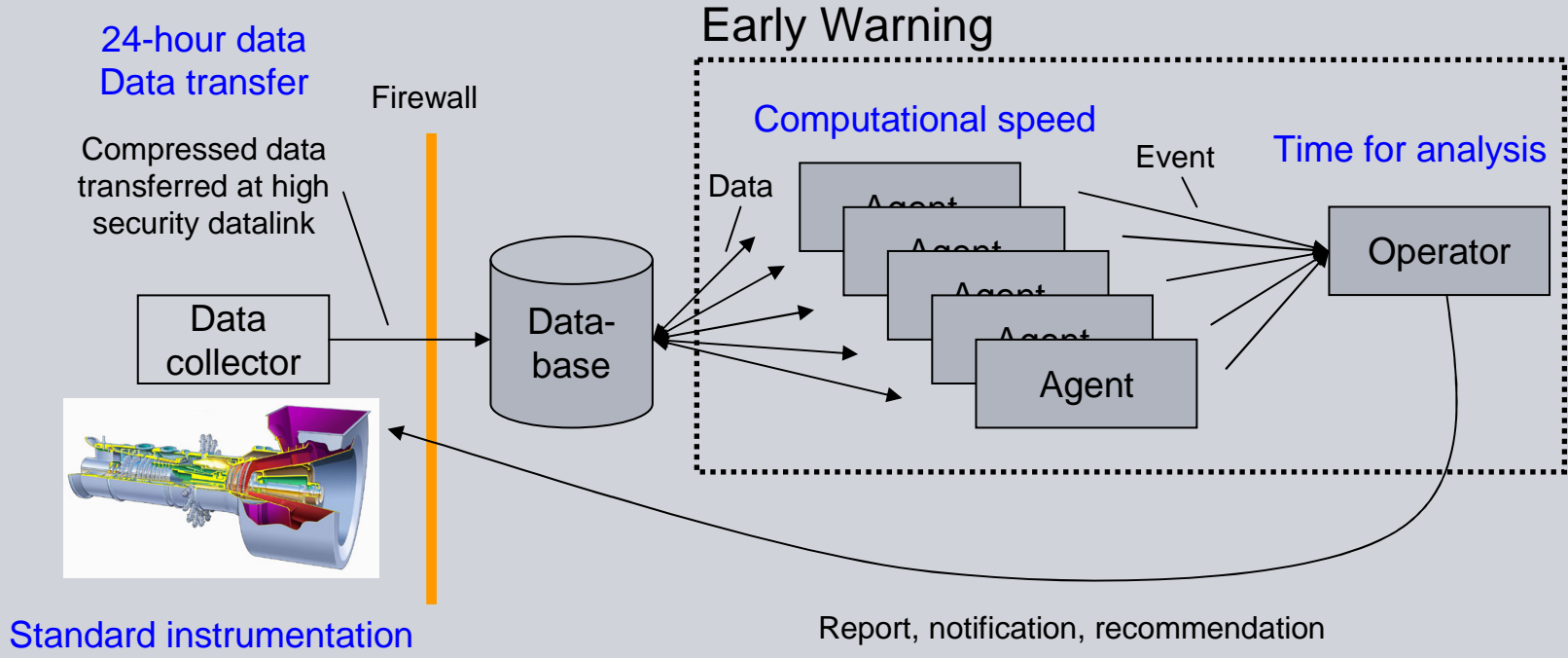

Vibration

Run-up (warm, cold)

Run-down

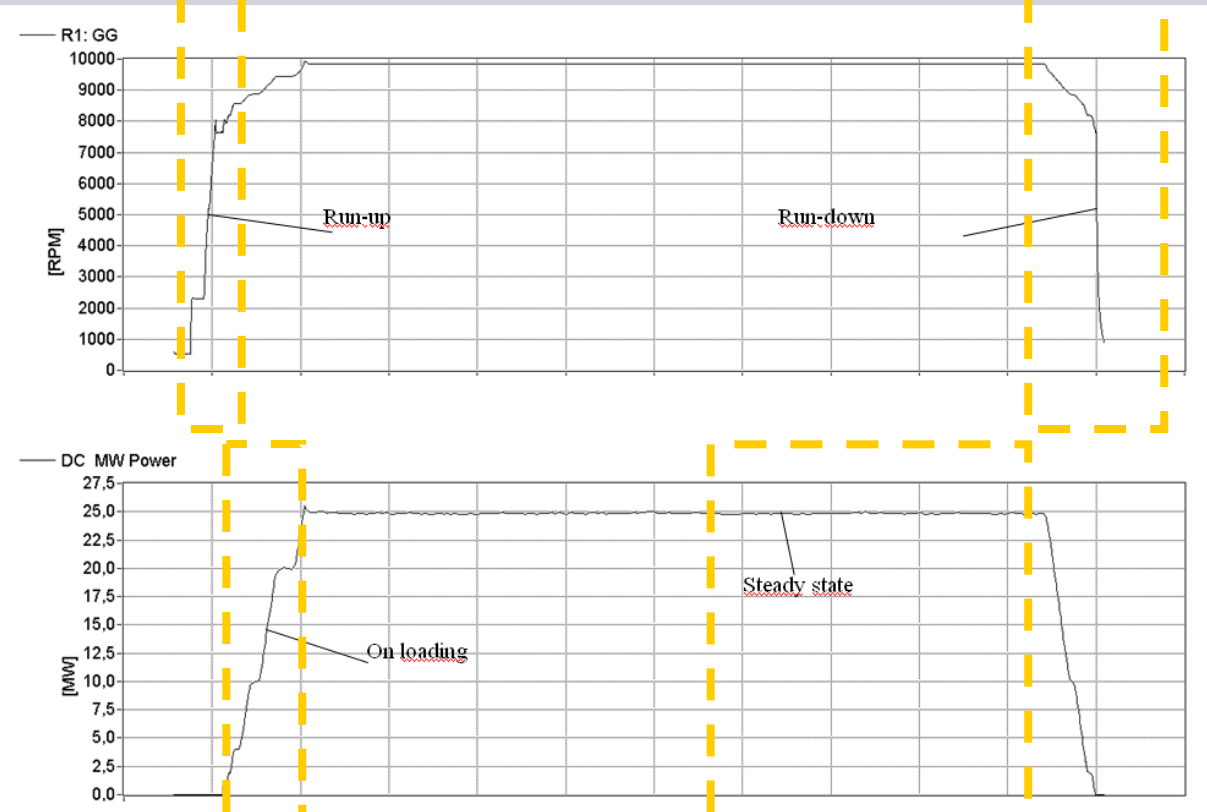

On-loading

Steady-state

Combustion

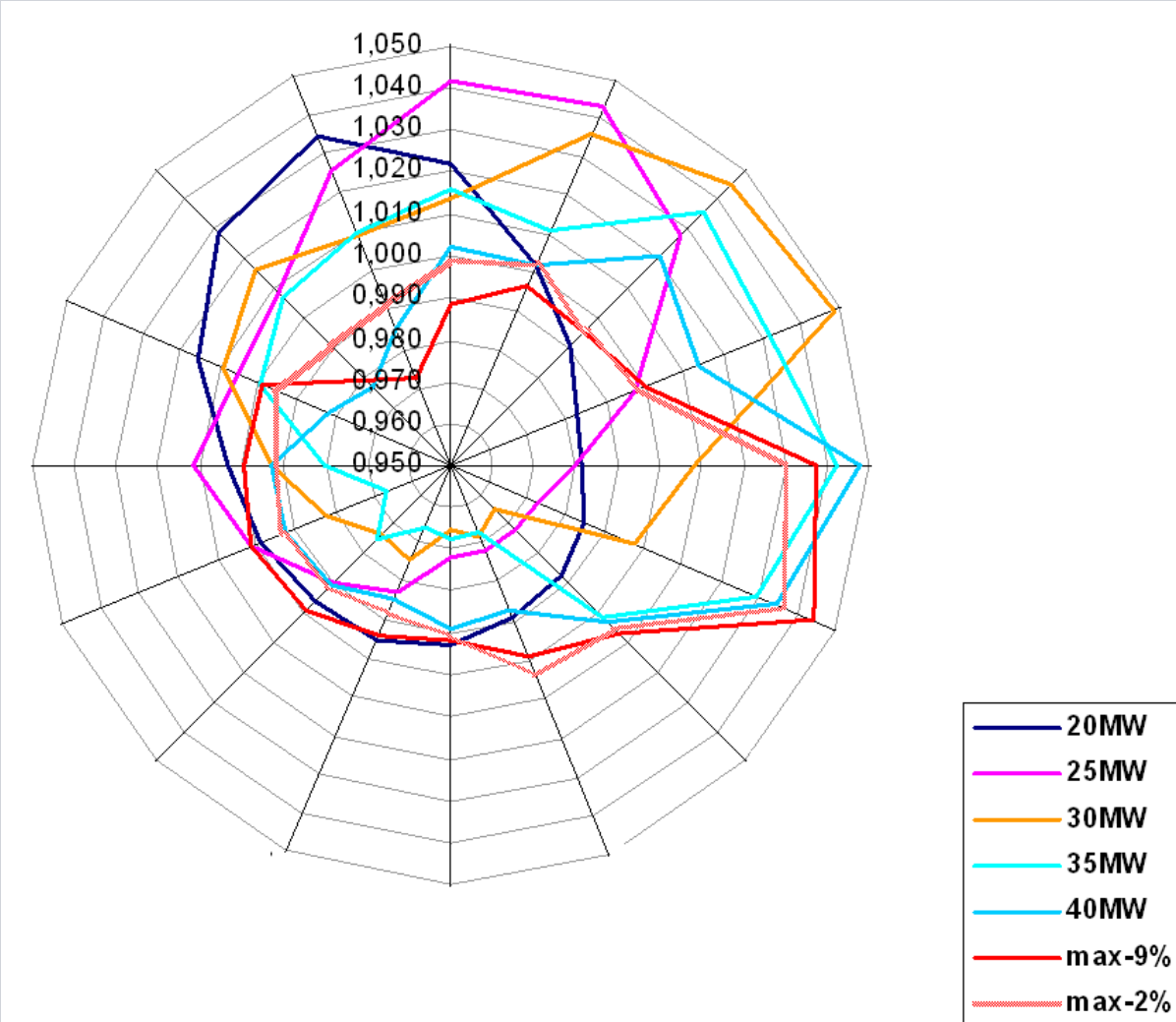

Performance

Rules
Thresholds

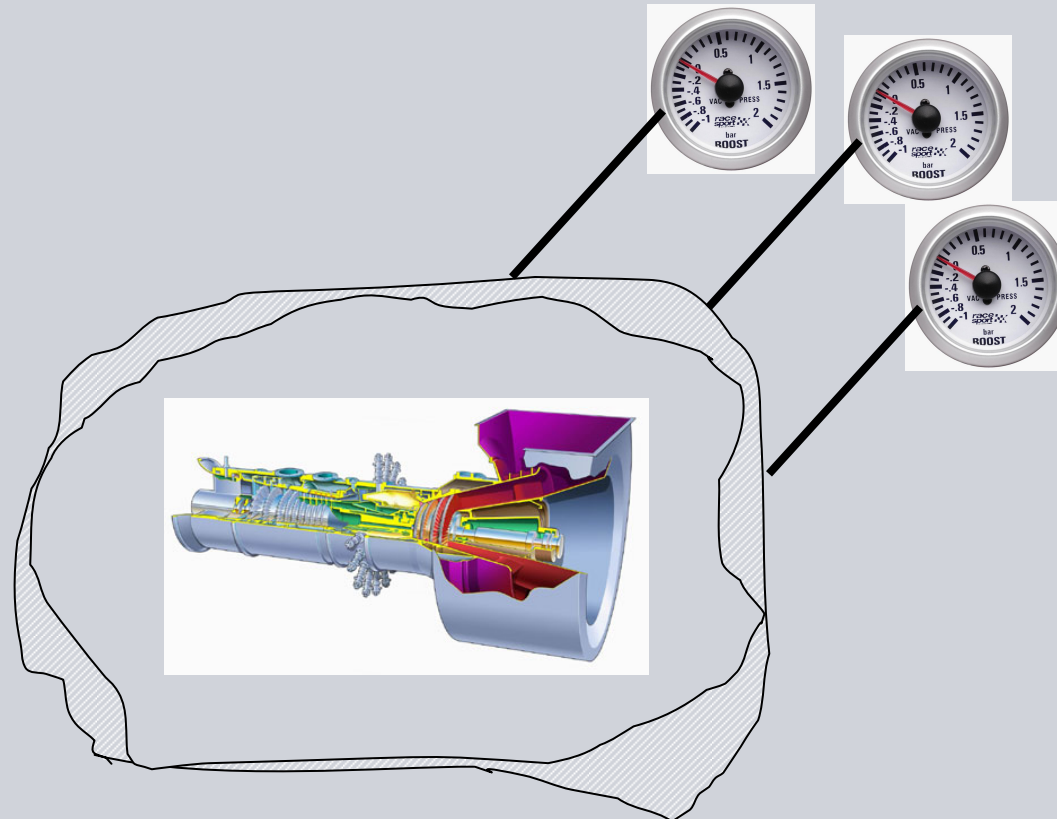

Some aspects on models used

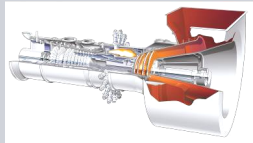

	Data-driven models	First principles models	Hybrid models
Knowledge needed	Overall (in-out)	Detailed	Detailed
Data for construction	Many operating points	Few operating points	Few operating points
Transparency	No	Yes	Yes to some degree
Computation speed	Real-time	On-line	On-line
Time between tuning	Short	Long	Medium

Conclusions

- Domain knowledge and reliable data
- Specialist knowledge transfer to system
- Data-driven, first principles, hybrids
- Deterioration
- Adaptation
- Specialist On-line!

8/5

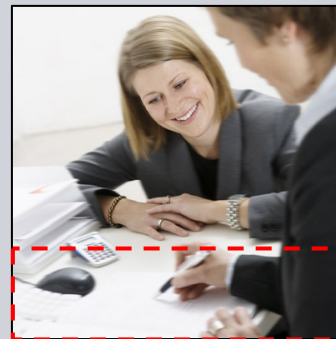

24/7

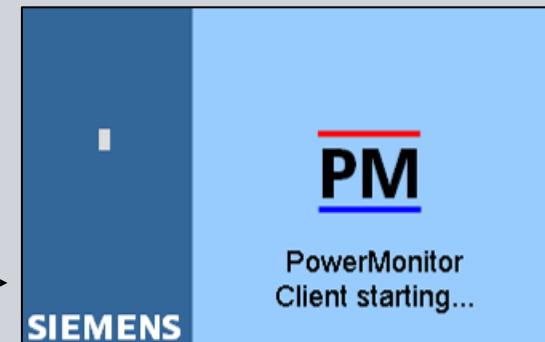

Capture Data and Knowledge in Models for Remote Monitoring

SIEMENS

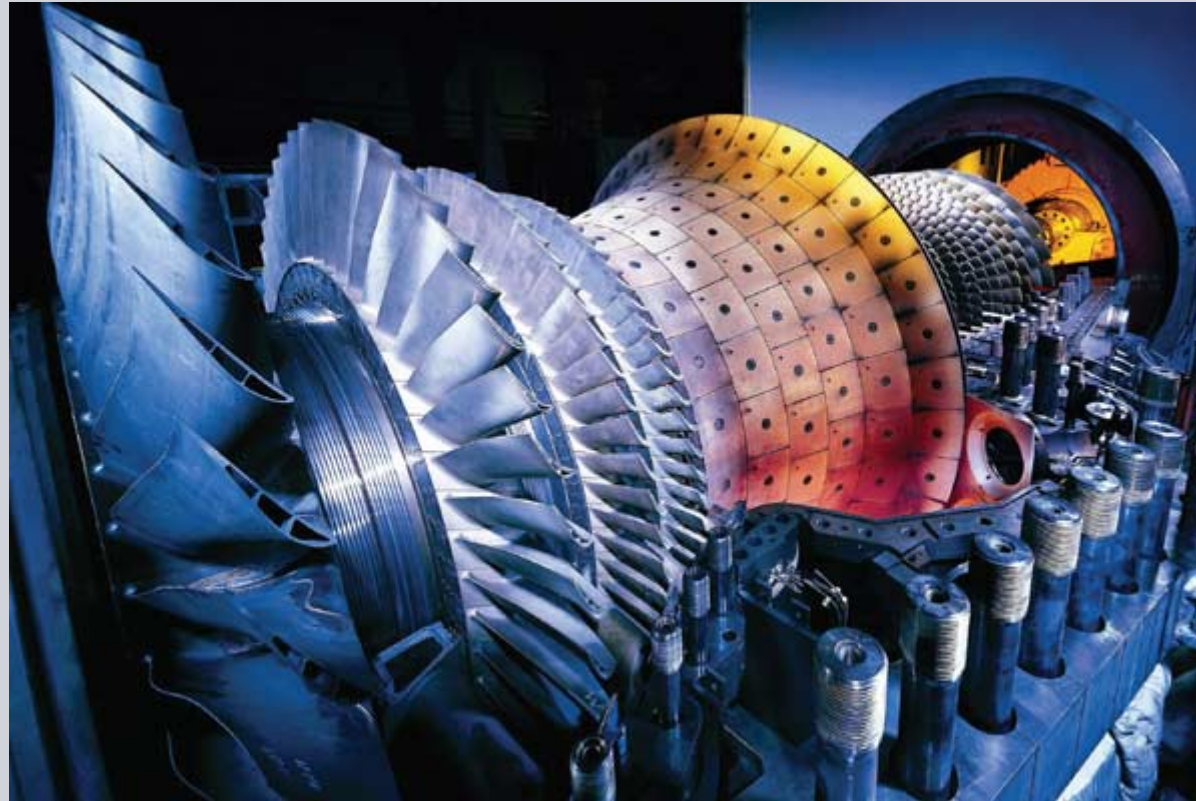

Christer Karlsson, PhD
Siemens Industrial Turbomachinery AB

Siemens Industrial Turbomachinery AB